

DRP: A Novel Approach for Requirement Planning in Supply Chain Management

Chandra Sekhar J V D, Balasubramanian V

School of Computing Science and Engineering
VIT University,
Vellore - 632014, India.

Abstract— Managing the inventory of heterogeneous products among the different companies across the globe is a crucial task for any product based company. The objective of new system **DRP** is to control the inventory at the customer site (VMI) to the lowest permissible level defined as **Minimum Inventory**. This is achieved by creating a **Supply Chain Model** that contains a network of **Demand Sites** and **Supply Sites** along with the **transit time** and other parameters for each product consumed by the Customer. This model is used to determine availability (**Stock**, **FABOOTS**, **VMI** and **GIT**) at the **Supply & Demand site** and the **Demand at the Demand Site**; and use this information to generate replenishment plan and trigger shipments just in time (**JIT**) such that there is no stock out at the customer site nor there is inventory build up at the customer site. **Minimum and Maximum inventory** is decided by a complex business function and is an agreement between company and the Customer. The System also provides an interface to the user to define the **Supply Chain Model** and its various entities and also to validate the output and make necessary changes before triggering subsequent operations like **Shipment generation**.

Key Words: Supply Chain Model (SCM), Just In Time, Distribution Planning, **DRP**.

I. INTRODUCTION

Resource management and product planning are two considerable things in supply chain model. Just-In-Time model is one of the techniques that give the best results for the inventory management but when the product company deals with heterogeneous products among different customers then JIT will not sufficient to solve the purpose of the inventory management system.

Just-In-Time (JIT) is the technique that attempts to improve any business in the aspect of return of investment such that there would be no underflow of the stock at the same time there should not be over dew of any product. This paper brings the new model that will enhance the performance of inventory management system. **DRP** is based on the **JIT**. If the production company handles the **B2B** relations then it will be involving in both long term and short term demands. So the stock policy **SCM** should handle all the situations to maintain inventory management System. This **DRP** mainly deals with the **B2B** relations. Distribution planning involves managing sales forecasts, creating master schedules, and running **DRP**.

Distribution Requirements Planning is a key tool for the planning and control of a company's distribution activities [1]. Supply is measured against forecast and actual demand and actions are suggested to ensure a high level of customer service. The timely provision of accurate strategic information allows for more informed business decisions.

The function of **DRP** is to determine the replenishment quantity for a particular time period [8]. The inventory management is based on the time lines like daily, weekly or monthly demands. So the planned orders at the branches are fulfilled based on the **DRP** logic. The **DRP** logic decides what quantity at which location needs to be supplied on what date. In the case of multilevel distribution networks, this distribution process can continue down through the various levels of regional warehouses (master warehouse, factory warehouse, etc) and become input to the master production schedule [2]. Demand on the supplying sources is recognized as dependent and standard **DRP** logic applies.

In certain cases where the distribution is for a limited number of items, but a balance must be maintained between multiple warehouse sites [4], master schedules based on actual schedules sales orders and sales forecasts may be used to drive the planning process through standard **DRP** logic[7]. This may result in master production schedules for one or more production sites.

II. RELATED WORK

The Supply chain model is deals with the some important terms for better readability.

Shipto id: shipping id where the goods should be. Id will include the Sequence Id of the product.

- Customer Association: the customer is related to which association it belongs to like **NKWW(Nokia)** **SVWW(sony)** **BOSH** etc. This term will be used when we are using the **B2B** applications.
- Commercial Product Code: the product which they have order form the customer perspective.
- Customer Partnr : commercial Product Code will be mapped to companies products this number indicates that number.

We have two codes related to product because as the producer, developing the same kind of goods for different customers will be same. Sometimes the material could also be same. For such situations according to the company the part numbers will be similar to the other products.

If multiple distributors or warehouses inventories are present, the system should try to adjust the inventories at the warehouses by shifting available units between distributors based on customer defined parameters that

shows the level at which inventories may interact with one another.

III. SYSTEM MODEL

The complex system design has different modules that will enable both the customer and producer to interact with the system. The designed System is able to take both short term and long term demands. Different modules of the DRP will inter connect through each other such that the distribution work is load balanced.

A. Interfaces in the Systems

The system has different interfaces within it for various inputs and/or outputs:

- BM: Backlog Management Application for aligning the ST Backlog to cater for increase or decrease in Customer Demand.
- EID (E-Immediate Delivery) Application for triggering shipments JIT.
- DV (Demand Visibility): Application for receiving Demand from the customer and sending the same to DRP in a pre-determined format.
- Min Max Application for the computation of Minimum and Maximum inventory levels based on the Customer Demand.
- B2B for exchange of information over the wire. Information pertaining to Customer Demand, Shipment Proposals, Inventory levels and Alerts, etc.

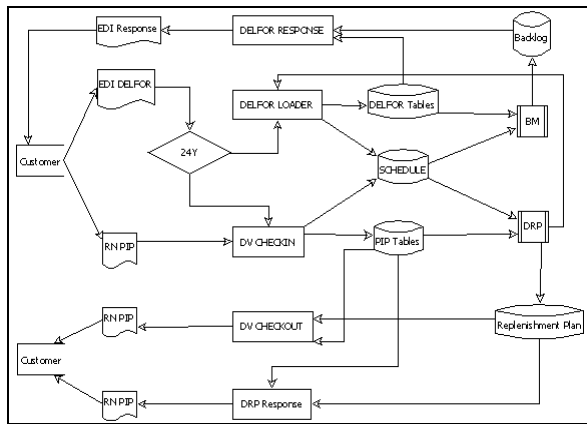

Fig 1 system model

B. Module Description:

BM: The aim of BM (Backlog Management) tool is to update the backlog of the company based on the DELFOR. DELFOR (DELivery FORecast) message is received on a regular basis (daily or weekly or twice a month...) via EDI or B2B and contains customer-rolling planning. It is a full picture of the customer request. For a given customer-ship-to and product, the last DELFOR message deletes and replaces

all the previous messages. Message sent by the customer. DELFOR message is received on a regular basis (daily or weekly or twice a month...) via EDI or B2B and contains customer-rolling planning. It is a full picture of the customer request. For a given customer-ship-to and product, the last DELFOR message deletes and replaces all the previous messages.

C. BM capacity:

- Updating usual (regional) Firm orders.
- Updating Firm orders for World Wide flow (also called Turn business Firm orders for World Wide flow).
- Updating customer Frame orders at customer-ship-to.
- Updating customer Frame order at regional or WW customer association level. The demand of all ship-to is consolidated in one unique frame order to replenish the buffer stock. All the ship-to of the association can consume this unique frame order or availability from the common dedicated buffer stock.

D. Sub DRP Module:

DRP is a systematic process for determining which goods, in what quantity, at which location, and when are required in meeting customer demand. DRP provides the basis for integrating this inventory information and physical distribution activities with the Manufacturing Planning and Control System.

The company has different customers. According to the Customers the product names are different but according to the company it is supplying all the required goods with the standard Inventory. All the process will be done with the below four terms.

E. Sub DRP Goal:

The DRP module goal is to get the net demand for a particular product on a particular day. Once the process goes from this module we can get the clear inventory information. Below diagram gives the detailed design of the net demand generation.

IV. SIMULATION MODEL

DRP system deals the heterogeneous requests so to handle so to handle all the requests, it takes the schema support. Below diagram shows the system architecture for the generation of net demand.

We are maintaining the xml files for configurations and determining the multi processing.

A. Event Monitor:

1. Event monitor will pick events from DE_EVENT table at fixed interval (Configurable in DaMainConf.xml) and makes its list.
2. After selecting the event it will update event status into **P**. If any error occurs into update it will remove that event from event list.
3. Successful updated events will be put into event queue.
4. On shutdown event it will stop putting request in event queue and main will stop this service.

B. Event Logger:

1. Event logger will keep listening log queue.
2. If any log event logger it put log into DE_EVENT table. For successful demand adapted, these will populate DE_EVENT_DETAILS (from demand loaded event) table also.
3. It will keep processing until it will find shutdown request and log event queue become empty. On shut down request it will keep processing till queue become empty. When queue become empty it will be shut down.

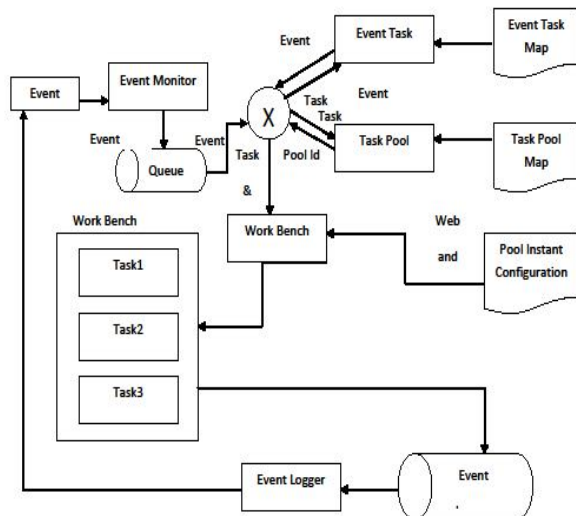

Fig 2 simulation model

C. Event Router:

1. Event Router will listen to event queue.
2. It will start all initialize and start all workbenches. Each work bench will have its own ID and an executor service. Executor service will have pool of threads to perform a specific task. ID and number of threads will be extracted from RouterThreadPool.xml.
3. For received events it will update event status to **F** and will find tasks to be performed from EventTaskMap.xml.
4. After getting tasks it will look for workbench which will perform these tasks. Workbench will be taken from TaskPoolMap.xml.

5. After identification of workbench it will assign the task to particular workbench.
6. It will keep processing until it will find shutdown request and event queue become empty. On shut down request it will keep processing till queue become empty. Once queue become empty it supply shut down request to all work benches and wait for them to finish their tasks.

D. Demand Adaptation: (Generating the Net Demand)

It will be triggered for demand loaded event. ShipTo, product, part number, schd ind and status will be mandatory input for demand adaptation. There will be configurations for the each product. We have different status flags for products to indicate how much process has done. Based on these flags only the system can decide whether a particular product should go through some process or not.

For demand loaded with status 50 and 04 it will not adapt the demand. It will only adapt the gross demand if gross demand adaptation flag is set Y and Net Demand only if Net demand adaptation flag is set Y. It will put demand adapted event for successful adaptation and adaptation not required.

In case of failure in demand adaptation it will put failure event for demand adaptation.

For successful demand adaptation it will set demand status to 03 for input demand while for adaptation not required it will set demand status to 01 which is in status 00. For successful demand adaptation and adaptation not required it will set event status to S, for failure it will get updated to U.

Demands for which adaptation is required it will extract the configurations. GAPS and OVERLAPS are optional configuration, others are mandatory. If any mandatory configuration is missing adaptation will be finished with error.

Based on event details (cp, pn, shipto, asscn, schd ind) and Horizon configuration (demand types), list of demands will be prepared. Demand list will not consider demands with status 50 and 04. To proceed further at least one demand will be mandatory. After preparing demand list, each demand will be elaborated.

The system is flexible to user for giving the start date of the production and even for start day of the week. So for configuring such new demands there will be situations that some demand will be delinquent. Remainder quantity will be assigned to first demand. Now Blending process will start. In Blending we will calculate Start date and end date for each demand to be blended based on Horizon configuration.

E.g. G: 10|F:20 First demand will start from today date to today + (remaining days in current week + (10-1)*7). Second Demand will start from (End date of demand one + one day) to (Start Date of demand 2 + 20 * 7).

In blending, first demand delinquency will be considered. E.g. G: 10|F:20 delinquencies will be taken for gross demand only. Demand before today will be considered as delinquent. Demand will be taken on the basis of date calculated date from Horizon configuration. Now demand will be clubbed on the basis of Granularity_Output flag except for delinquency demand. Weekly demand will be clubbed on

preferred day. For Weekly First period if preferred day is delinquent then it will get clubbed on today date. If preferred date is less than previous demand date then it will get clubbed on schd date of that demand. In first period we will get quantity of remaining days in week. For monthly, demand will get clubbed on first day of month. For first period demand will start from schd date of starting demand. In first period we will get quantity of remaining days in that month. First Day of month will be based on calendar configured in DB. Delinquent will be attached to demand based on its configuration. For NC delinquent demand will remain as it is. FD: Delinquent quantity will be added to first demand. TD: If demand is available on today date then demand quantity will

be added to that demand otherwise new demand will get created on today date.

After all clubbing rounding will take place on the basis of rounding configuration. For configured product/customer all demands will get rounded against bulk quantity. Upper rounding will take place. Excess Quantity will get adjusted in next period demand. After rounding demand type of output demand will be changed to demand type configured on BLENDED_DEMAND_TO_BE_STORED_AS configuration. Output demand will be stored after cleaning of demands (will be moved to HSCHEDULE) for same.

V. RESULTS AND DISCUSSION

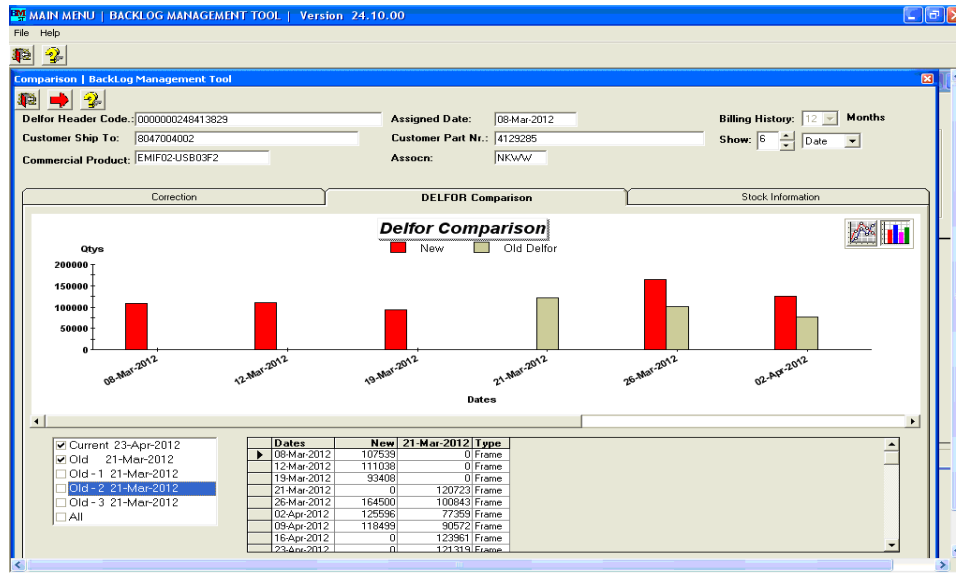

Fig 3 The above diagram shows the comparison of the demands between the two demands of the same product in time line.

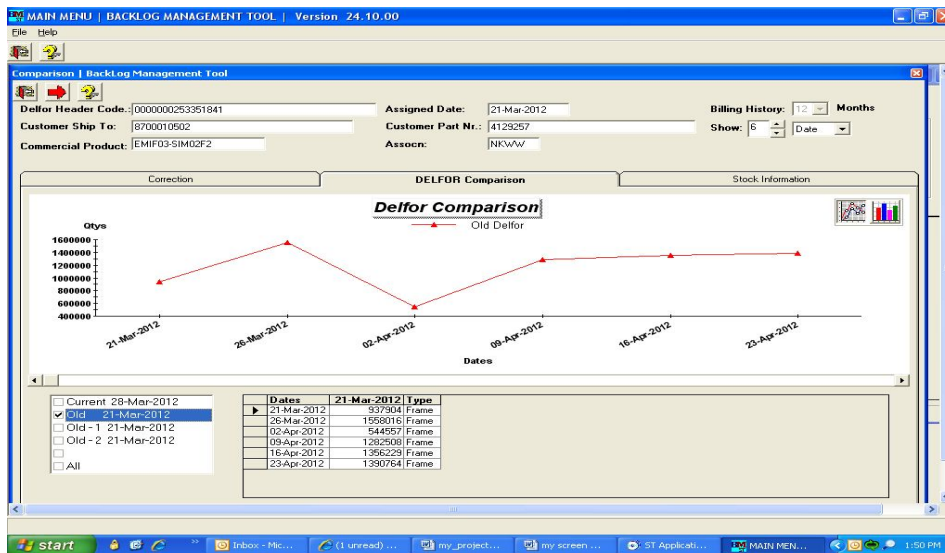

Fig 4 This graph shows the demand before calling the new system and the showing the demand at weekly level.

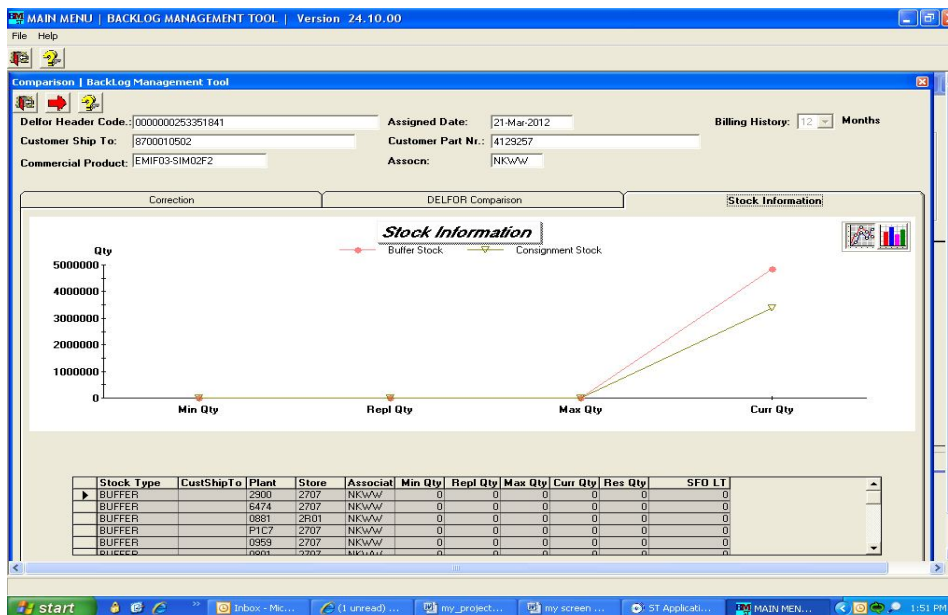

Fig 5 from the above graph we can get the variations of the demand before applying and after applying the system.

VI. PERFORMANCE EVALUATION

With the new DRP the maximum amount can be left out is rounded qty -1, which can be shown as below for 3 weeks demand. Let us simulate the theory with the rounding quantity is 1000. According to our system the over dew should be at maximum $999 < (1000 - 1)$.

TABLE 1 DRP demand

Changed to daily demand	Net Demand	Demand date from the customer	Requested Demand
23-Apr-12	2000	23-Apr-12	1300
24-Apr-12	1000	24-Apr-12	1300
25-Apr-12	1000	25-Apr-12	1300
26-Apr-12	1000	26-Apr-12	2600
27-Apr-12	0	02-May-12	345

28-Apr-12	1000	09-May-12	7326
29-Apr-12	0	16-May-12	8344
30-Apr-12	0	23-May-12	8344
01-May-12	1000		
02-May-12	0		
03-May-12	0		
04-May-12	0		
05-May-12	0		
06-May-12	0		
07-May-12	0		
08-May-12	0		
09-May-12	2000		
10-May-12	1000		
11-May-12	1000		
12-May-12	1000		
13-May-12	0		
14-May-12	1000		
15-May-12	2000		

- [1] Alessandri, A, Gaggero, M and Tonelli, F “Min-Max and Predictive Control for the Management of Distribution in Supply Chains” Transactions on Control Systems Technology: 1075 – 1089(2011).
- [2] Franks, S. “Beyond lean [supply chain management]” Transactions on IET JOURNALS & MAGAZINES : 38-40(2003)
- [3] Zhang, G.P.; Hill, C.A.; Yusen Xia; Faming Liang. “Modelling the Relationship Between EDI Implementation and Firm Performance Improvement With Neural Networks” Transactions on Automation Science and Engineering: 96 – 110 (2010).
- [4] Salmela, H.; Toivonen, S.; Scholliers, J. “Enhancing supply chain security with vulnerability management and new technology” Transactions on Intelligent Transport Systems, IET: 307 – 317 (2010).
- [5] Giovannucci, A.; Cerquides, J.; Rodriguez-Aguilar, J.A “Composing Supply Chains Through Multiunit Combinatorial Reverse Auctions With Transformability Relationships Among Goods” Transactions on Systems, Man and Cybernetics, Part A: Systems and Humans: 767 – 778(2010).
- [6] Callaway, R.D.; Devetsikiotis, M.; Viniotis, Y.; Rodriguez, A. “An Autonomic Service Delivery Platform for Service-Oriented Network Environments” Transactions on Services Computing:104-115(2010).
- [7] www.geac.com
- [8] www.ietdl.org

The total over dew is $15000-14171 = 829$. So with this new system the company efforts accurately managed and demand fulfilment is now at the optimum level.

If we observe the above graph it is giving the clearer picture for generating the net demand. The stock will be generated accordingly. The above diagrams show the performance of the inventory management. Before the batch run after the batch run. This graph indicates that it reduced the effort and now generating the required but not over dew at the same time we can see the demand is sufficient to fulfil the requirement of the customer.

VII. CONCLUSION AND FUTURE WORK

DRP controls the inventory of the production company at the best possible way. Through this system the customer satisfaction will be high because at any point of time the goods will be available. The producer satisfaction is also high in producing the goods because there will not be any over dew of what is required. DRP system gives the flexibility to customers for giving the order and its configuration.

The future work will be applying this system for the different supply chain managements. Currently this system is used in the field of Stock Requirement Planning. This can be extended to any Resource planning of any organization. The extension of DRP system will be used in Load Balancing of Distributed system.

VIII. REFERENCES